

## General Specifications

Supply Input.....	7-40V 5A Examples: Digikey part 102-1337-ND or 62-1047-ND (enclosed)
Dimensions.....	2.25" X 2.25" (57mm X 57mm) square, 1.0" (25mm) thick
Maximum Speed.....	59900 encoder counts/second
Operating Modes.....	PC controlled or standalone
PC Control.....	Up to 16 controllers can be daisy-chained together.
Communications Protocol.....	USB, RS232, RS485, and CAN Bus. Direct USB, RS485, and CAN Bus connections built in. USB connector is USB micro.
Control Protocol.....	Compatible with devices that use the Cavro DT or OEM protocol. Can use EZCommander™ Windows application or serial terminal program such as HyperTerminal to issue ASCII text-based commands.
Motor Compatibility.....	Typically compatible with any servo motor that is 3" or smaller (size 23 or smaller). Outputs can regulate to any motor voltage via software commands. E.g., 3V motor on 24V supply.
Mating Connectors.....	For power and motor, AMP MTA 100 series. For signal connections, HIROSE DF11 series. Recommended tools: see website. (See Application Note 131021 for non-standard connector options.)
Digital/Analog Interface.....	Accepts 8 opto-electronic or 16 mechanical switch inputs, or 16 ADC inputs. ADC inputs accurate to 7 bits; can be modified to 10 bit (contact factory). Signal Levels: <0.8V Vlow; >2V Vhigh (TTL compatible). Threshold set at 1.23V; can be changed via programming Optical switch specifications: Transistor optical switch with IC> 1 mA @ IF=20mA. Examples: Digikey QVA11134 or H21A1; Honeywell HOA1887-012 or HOA1870-33 (prewired); OPTEK OPB830W11 (prewired).
5V Output Current.....	600mA total (power is available for encoders and sensors)
Encoder Interface.....	Max. freq. 4 MHz, 5V signals (3.3V upon special request)
Operating Temperature.....	-20 to 85 °C PCB copper temperature
Relative Humidity.....	10% to 90% non condensing (operating and storage)

## Intelligent 4-axis servo controller/driver for Brush or BLDC, Quad Encoder

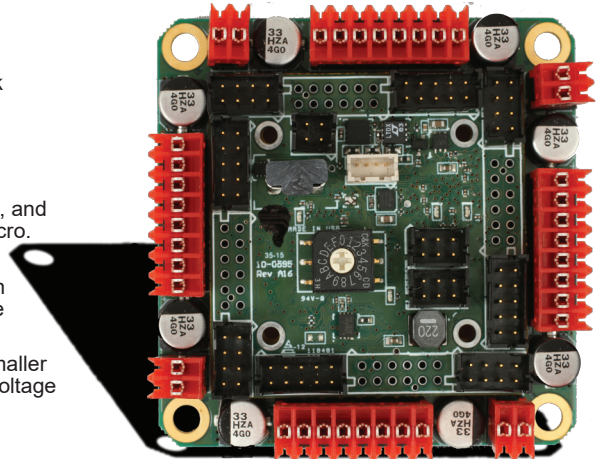

Model EZQUADSERVO approx. actual size

For rapid implementation of multi-axis servo motor solutions in products requiring automation. Controls four fully independent motors.

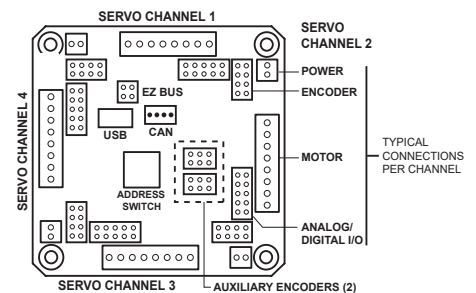

### ANALOG/DIGITAL I/O CONNECTORS (4)

Mating connector: HIROSE DF11 Series 10 pin DF11-10DS-2C

Pin	Function	Notes
1	Switch 2 in / Digital 2 <sup>0</sup> / Analog CH2	10k Ω pullup to 3.3V. Switch closure is to ground.
2	Switch 1 in / Digital 2 <sup>1</sup> / Analog CH2	10k Ω pullup to 3.3V. Switch closure is to ground.
3	Opto 1 LED Drive / Drive 1 (TTL)	See Note 1.
4	Opto 1 in/ Home / Lower Limit / Digital in 2 <sup>2</sup> / Analog CH3	10k Ω pullup to 3.3V. Switch closure is to ground.
5	Opto 2 in/ Upper Limit / Digital in 2 <sup>3</sup> / Analog CH4	10k Ω pullup to 3.3V. Switch closure is to ground.
6	Ground	Common input ground
7	Ground	Common input ground
8	Opto 1 LED Drive / Drive 1 (TTL)	See Note 1.
9	Driver 3 (open drain) 0.5A	For solenoids, etc.
10	Driver 4 (open drain) 0.5A	For solenoids, etc.

### ENCODER CONNECTORS (6)

Mating connector: HIROSE DF11 Series 8 pin DF11-8DS-2C

Pin	Function	Notes
1	Ground	Ground for encoder
2	Index	Input from encoder. High level must be >4.5V (external pullups may be required).
3	Chan A	Input from encoder. See comment for Pin 2.
4	+5V (V+)	Power to encoder
5	Chan B / SPI_MISO	Input from encoder. See comment for Pin 2.
6	SPI_MOSI	Slave input from master (master output)
7	SPI_CLK	Serial clock from master
8	SPI_CS2	Chip select

### POWER CONNECTORS (4)

Mating connector: AMP MTA 100 Series 2 pin, 20 GA, part 3-643818-2 Digikey part A31363-ND

Pin	Function
1	V+ (external supply) +7V to 40V
2	GROUND

### MOTOR OUTPUT CONNECTORS (4)

Mating connector: AMP MTA 100 Series 8 pin, 22 GA, part 3-643813-8 Digikey part A31111-ND

Pin	Function
1	HALL A (BLDC) / Connected to pin 5 (Brush)
2	HALL B (BLDC) / Not used (Brush)
3	HALL C (BLDC) / Not used (Brush)
4	+5V HALL sensor power (BLDC) / Not used (Brush)
5	HALL sensor ground (BLDC) / Connected to pin 1 (Brush)
6	Phase A power driver (BLDC) / Motor - (Brush)
7	Phase B power driver (BLDC) / Not used (Brush)
8	Phase C power driver (BLDC) / Motor + (Brush)

### RS485 CONNECTOR (EZ BUS)

Mating connector: HIROSE Series 4 pin, 22-30 GA, part DF11-4DS-2C

Pin	Function
1	Ground
2	V+ (external supply) +7 to 40V
3	RS485A
4	RS485B

**Note 1:** Each LED sensor input includes a series 200 Ω resistor to 5V. Resistor can be removed for sensors needing direct access to 5V. Max current draw is <200mA.

**Note 2:** The USB connector type is USB micro.  
**Note 3:** For CAN BUS connections, see other side.

## Mechanical Specifications

Outside connector pin numbering reads clockwise except where otherwise noted. Pin assignments typical per channel.

### CAN BUS CONNECTOR

- 1 CAN HIGH BUS
- 2 CAN LOW BUS
- 3 SIGNAL GROUND
- 4 RESERVED

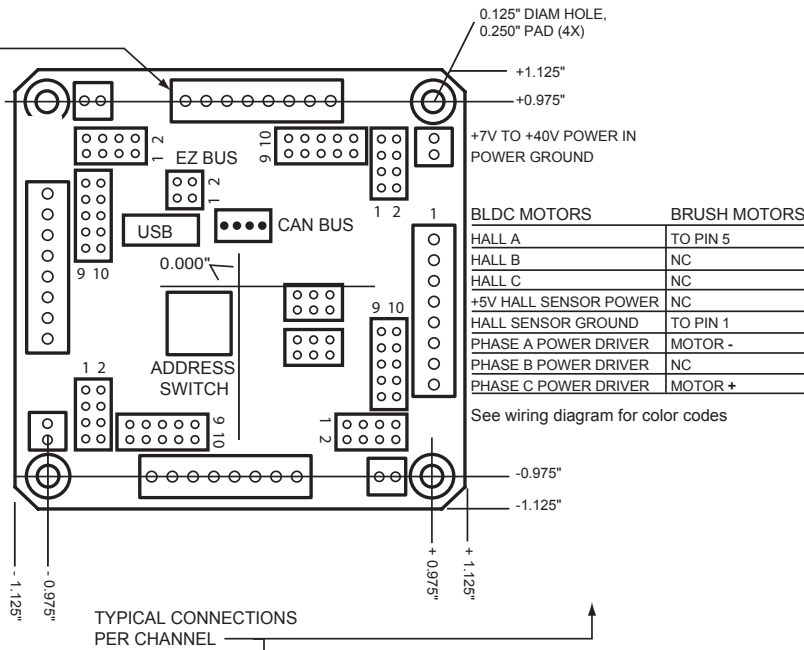

BLDC MOTORS	BRUSH MOTORS
HALL A	TO PIN 5
HALL B	NC
HALL C	NC
+5V HALL SENSOR POWER	NC
HALL SENSOR GROUND	TO PIN 1
PHASE A POWER DRIVER	MOTOR -
PHASE B POWER DRIVER	NC
PHASE C POWER DRIVER	MOTOR +

See wiring diagram for color codes

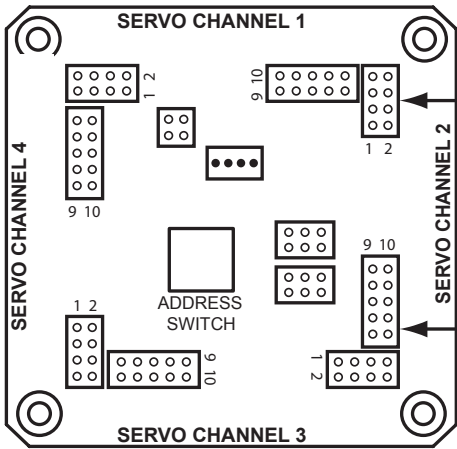

### ENCODER CONNECTOR

- 1 GROUND
- 2 INDEX
- 3 CHANNEL A
- 4 +5V
- 5 CHANNEL B/ SPI\_MISO
- 6 SPI\_MOSI
- 7 SPI\_CLK
- 8 SPI\_CS2

### ANALOG\_DIGITAL I/O CONNECTOR

- 1 SWITCH 2 IN / DIGITAL 2<sup>A</sup>0 / ANALOG CH2
- 2 SWITCH 2 IN / DIGITAL 2<sup>A</sup>1 / ANALOG CH2
- 3 OPTO 1 LED DRIVE / DRIVE 1 (TTL)
- 4 OPTO 1 / HOME / LOWER LIMIT / DIGITAL IN 2<sup>A</sup>2 / ANALOG CH3
- 5 OPTO 2 / UPPER LIMIT / DIGITAL IN 2<sup>A</sup>3 / ANALOG CH4
- 6 GND
- 7 GND
- 8 OPTO 1 LED DRIVE / DRIVE 1 (TTL)
- 9 DRIVER 3 (OPEN DRAIN) 0.5A
- 10 DRIVER 4 (OPEN DRAIN) 0.5A

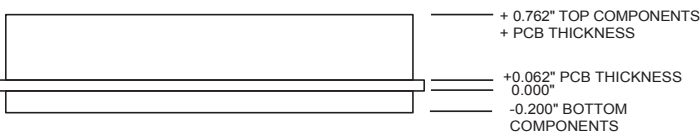

## Key Features

- Full-featured 4-axis position controller with power drivers
- Accepts four encoders plus two auxiliary encoders
- Four independent 5A BLDC drives
- 7V to 40V 5A operation
- Pre-wired for opto-switch and limit inputs
- Halt/branch on ADC value
- Halt/branch pending switch closure
- RS232, RS485, USB, or CAN bus-based communications
- Direct USB, RS485, and CAN bus connection built in
- Industry standard communications protocol
- Single 4-wire bus links up to 16 AllMotion products.
- Standalone operation with no connection to a PC
- 16 analog inputs (ADC) and 16 power on/off drivers
- Switch-selectable device address
- On-board EEPROM for user program storage
- Homes to opto or switch closure with one command
- Independent parameters for all axes (acceleration, velocity, currents, etc.)
- Fully programmable acceleration ramps and speeds
- Execution halt/branch pending switch closure

See EZQUADSERVO wiring diagram (on website) and/or user guide for application details.

## Ordering Information

Name	Order Number
EZQUAD 4-Axis Servo Controller + Driver.....	EZQUADSERVO
RS232 to RS485 Converter (option).....	RS485
Starter kit .....	SK-EZQUAD
RoHs-compliant	